



# HyperSWASH III

## Config Guide

Updated January 2025

Plan 11

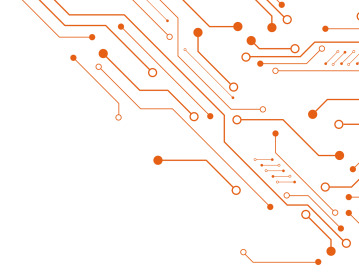

DIRECT  
SPRAY



TOP AND  
BOTTOM SPRAY



AIR KNIFE  
DRYER



TRACEABILITY



CONCENTRATION  
CONTROL



AUTOMATION



RINSE  
CONTROL



MES  
CONNECTIVITY



Automatic cleaning machine

Precise cleaning of PCBAs

Single chamber Spray-In-Air technology

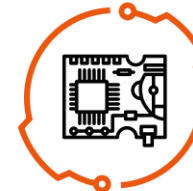

PCBA



DBC



MECHANICAL  
PARTS



**COMBO**  
Expanded capacity  
in 3 baskets



BASKETS



**TWINGO**  
Large & complex  
boards in 2  
frames



FRAMES



Application: **Standard SMD Assemblies**  
Capacity: **High Volume**  
Contamination solubility: **Easy to Moderate**

Application: **High Density SMD Assemblies**  
Capacity: **High Volume**  
Contamination Solubility: **Moderate to Hard**

## Features

- High performance cleaning machine for water-based chemicals
- High performance direct spray technology
- 5 stage process Wash, Pre-Rinse, 1<sup>st</sup> Rinse, 2<sup>nd</sup> Rinse, Drying
- Rapid direct drying by heated air knife
- Closed loop eco drain system
- Superb for high volume cleaning of electronic assemblies
- 2 in 1 - COMBO/TWINGO

## Applications

- Defluxing – removing all kinds of solder residues
- Cleaning of fine mechanical components
- Removing contamination from handling and board manufacturing, FOD
- Cleaning highly populated electronic assemblies with low standoff components such as BGA, CSP, BTC, QFN, MELF
- Cleaning of power electronics
- Cleaning of electronic assemblies requiring extra short process time
- Ideal for double-sided misprints on complex assemblies
- Cleaning before conformal coating and wire bonding

## Parameters

Machine dimensions (WxLxH)	2010 x 2075 x 2615 mm (max)
Weight (without liquid, accessories)	1 000 kg
Power supply voltage	3/N/PE AC 400/230 V 50 Hz
	terminal block AC 208/120 V 60 Hz

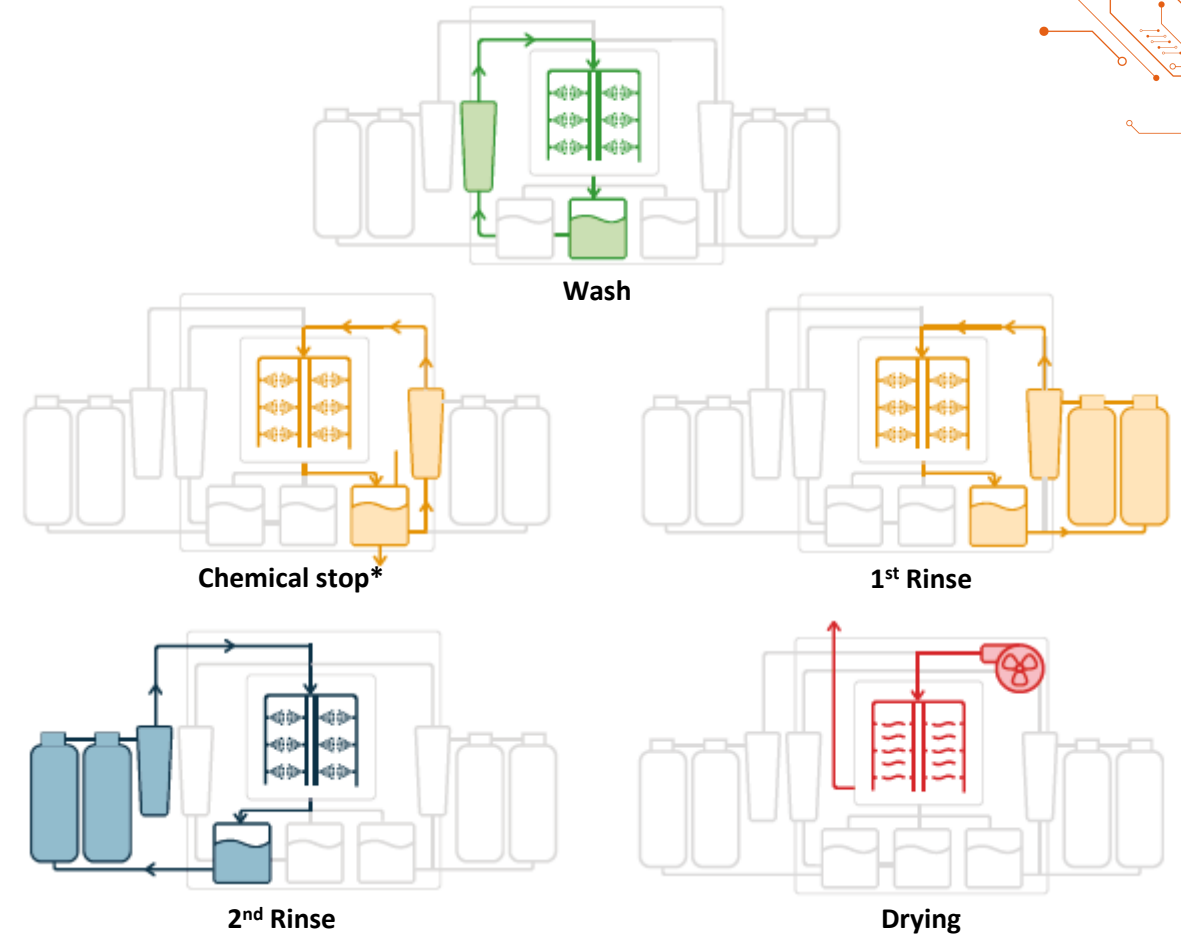

	MECHANICAL FILTERS							
		Wash		1 <sup>st</sup> Rinse		2 <sup>nd</sup> Rinse		DI water cart
HyperSWASH III (Open loop)	3	5 µm 20" length	3	1 µm 20" length	3	1 µm 20" length		
HyperSWASH III (Closed loop)	3	5 µm 20" length	3	1 µm 20" length	3	1 µm 20" length	2	1 µm 20" length

## Base

VM-00003872-X

**HyperSWASH III: Wash + 1<sup>st</sup> Rinse + 2<sup>nd</sup> Rinse + Drying**

- Spray-In-Air cleaning system base
- Cleaning chamber with backlight
- Air-Drying unit with heating up to 110°C
- Anti-collision system of nozzle arms
- Spillage tray to hold leaked liquid
- Extraction Flap
- 3 liquid tanks with heating and piping
- Mechanical filtration in 3 stainless steel filters (9x 20" filter pads)



## Power Supply

VM-00003935-X

**Power Supply 230/400VAC, 50/60Hz**

- Switchboard, electrical wiring
- Control system with touchscreen HMI

VM-00003934-X

**Power Supply 120/208VAC, 60Hz**

- Switchboard, electrical wiring
- Control system with touchscreen HMI

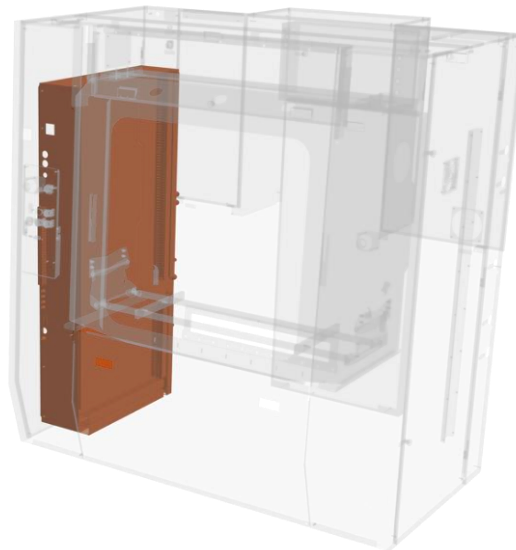

## Pumps

VM-00004466-X

**Pumps 50Hz**

- Pumps for all three liquid tanks

VM-00004465-X

**Pumps 60Hz**

- Pumps for all three liquid tanks

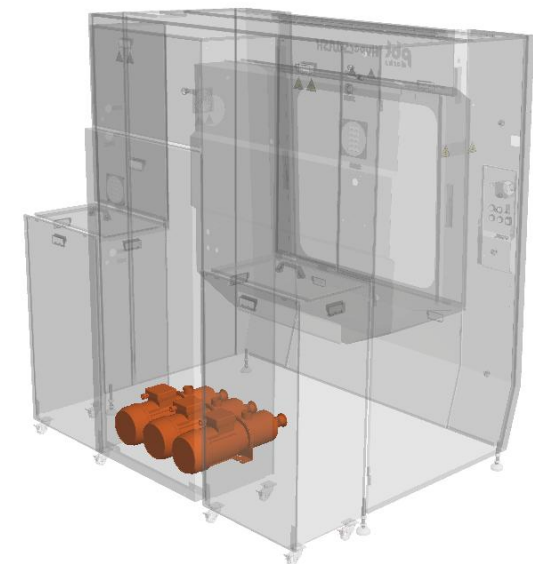

## Door & Loading

### VM-00003869-X

#### Manual door

- Manually operated glass door
- Safety lock system
- **Only with Manual loading**

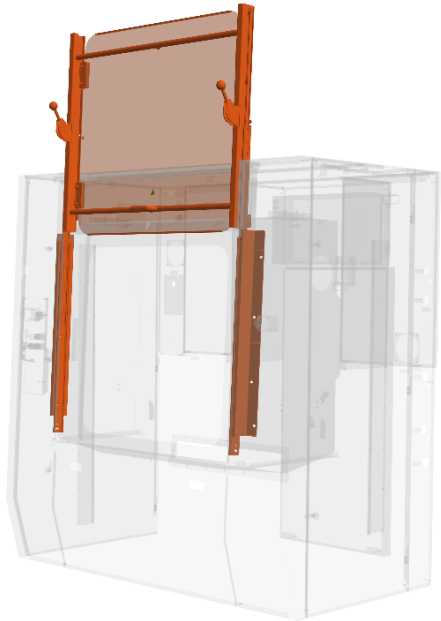

### VM-00004527-X

#### Docking with manual loading incl. pushcart

- Pushcart incl. docking system
- Basket/Frame holder base on pushcart
- **Only with Manual door**

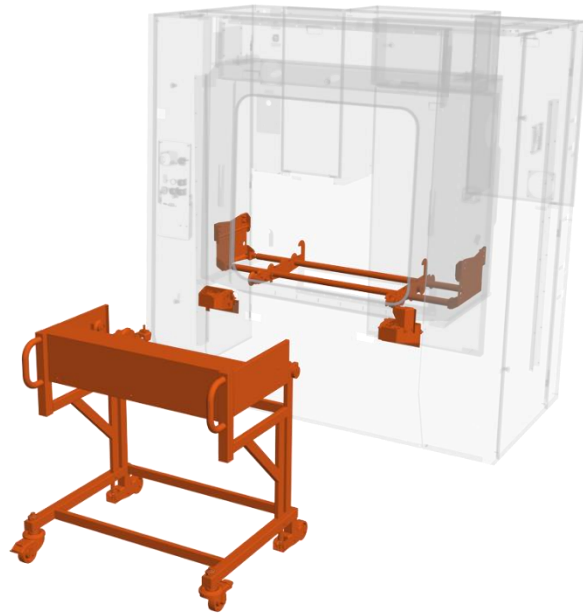

### VM-00003864-X

#### Automated door

- Automatically operated glass door
- Safety lock system
- **Only with Automated loading**

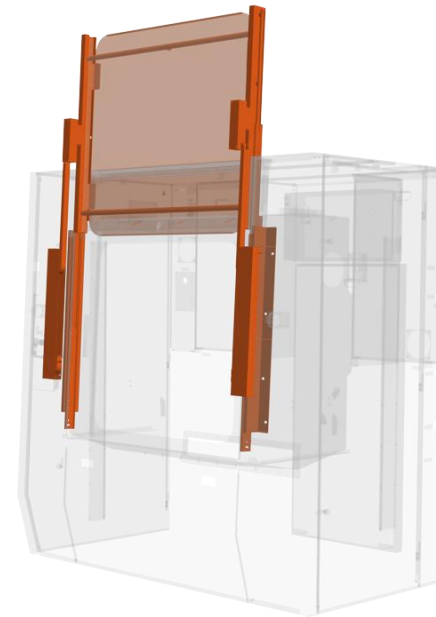

### VM-00004458-X

#### Docking with automated loading incl. pushcart

- Pushcart incl. docking system
- Transloader – automated loading and unloading into/from the chamber
- Basket/Frame holder base
- Human safety system
- **Only with Automated door**

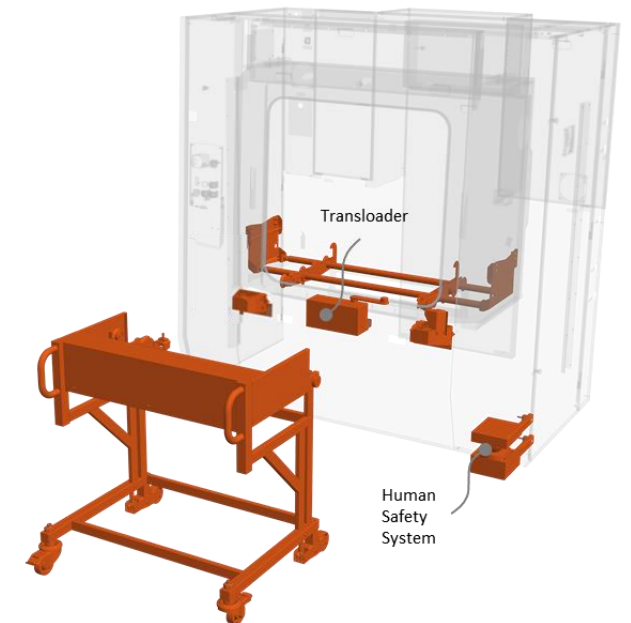

## Nozzle arms

VM-00004317-X

### Nozzle & Air Knife Arm COMBO 2

- Spray nozzle arm for 2 baskets
- Air knife arm

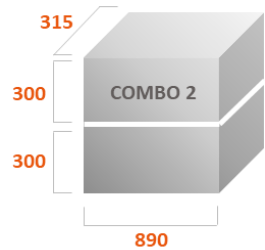
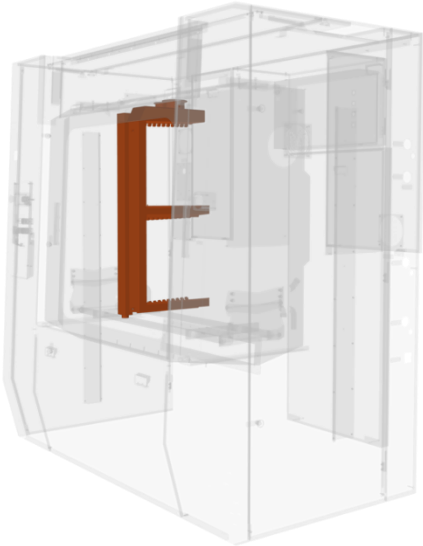

*Max usable chamber space*

VM-00004319-X

### Nozzle & Air Knife Arm COMBO 3

- Spray nozzle arm for 3 baskets
- Air knife arm

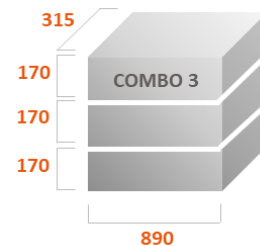
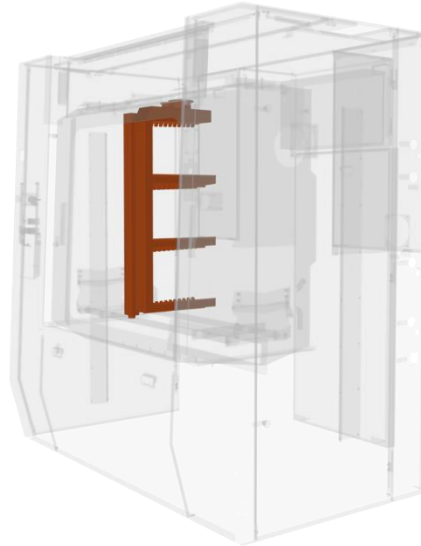

*Max usable chamber space*

VM-00004320-X

### Nozzle & Air Knife Arm TWINGO

- Spray nozzle arm, nozzles in double-row for 2 frames
- Air knife arm

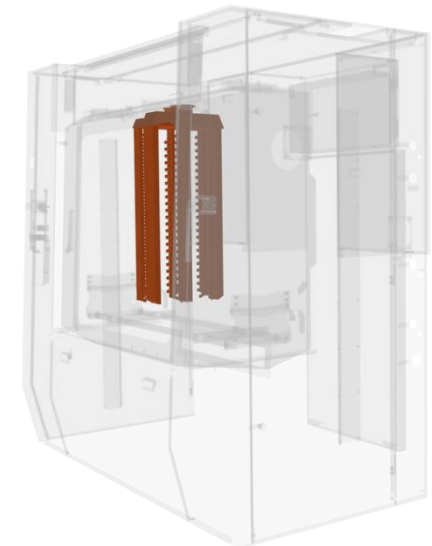

*Max usable chamber space*

## Filtration

### VM-00011510-X

#### Closed loop DI water cart for 1<sup>st</sup> Rinse (Carbon, Mixedbed Large)

- Closed loop for 1<sup>st</sup> rinse with chemical filtration and a mechanical filter
- External cart containing large Mixedbed and Carbon, 1 $\mu$ m 20" filter cartridge

### VM-00011511-X

#### Closed loop DI water cart for 2<sup>nd</sup> Rinse (Carbon, Mixedbed Large)

- Closed loop for 2<sup>nd</sup> rinse with chemical filtration and a mechanical filter
- External cart containing large Mixedbed and Carbon, 1 $\mu$ m 20" filter cartridge



### VM-00011408-X

#### Open loop 1<sup>st</sup> Rinse

- No filtration cart

### VM-00011409-X

#### Open loop 2<sup>nd</sup> Rinse

- No filtration cart

## Signal tower

### VM-00004495-X

#### Signal tower standard (green/blue/red)

- Audio and visual effects to signal individual processes

### VM-00004505-X

#### Signal tower white (green/orange/red)

- Audio and visual effects to signal individual processes

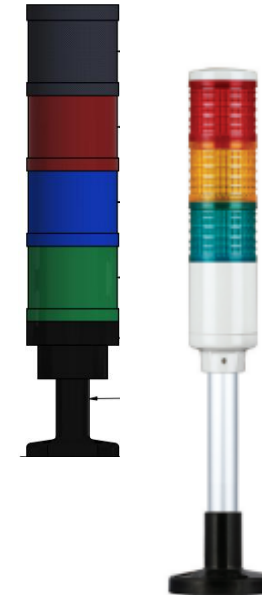

## Holders

### VM-00004964-X

#### COMBO basket holder

- Adjustable basket holder arms for 1, 2 or 3 baskets
- To be used on pushcart
- Baskets are sold separately

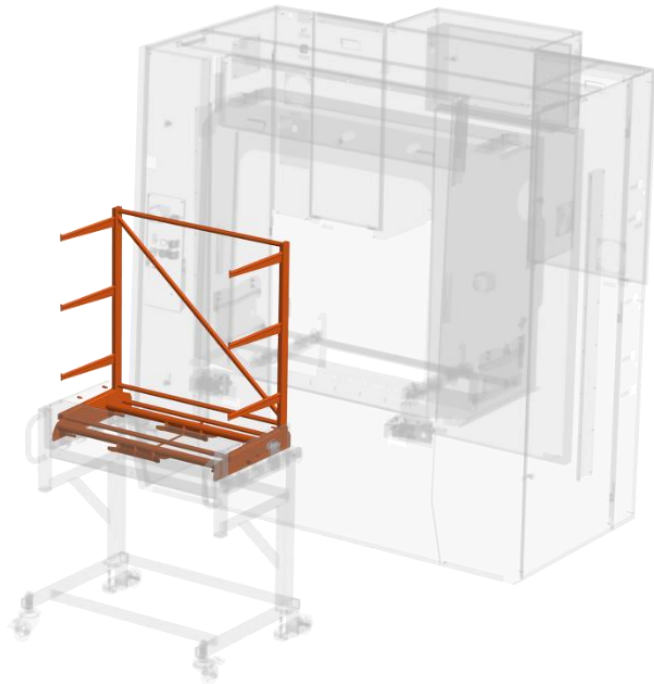

### VM-00004307-X

#### TWINGO frame holder incl. 2 basic frames (2x 740x695 mm)

- Double frame holder including 2 FIXED basic frames
- To be used on pushcart
- Usable space of fixed frames: 2x 740 x 695 mm

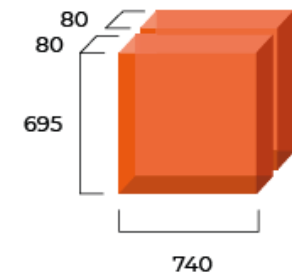
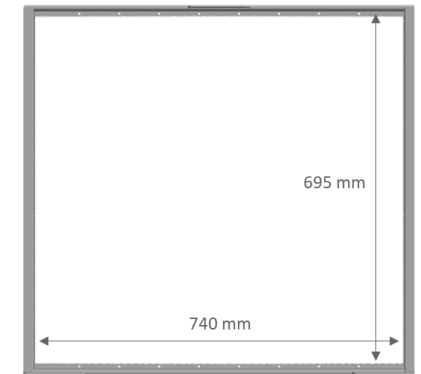
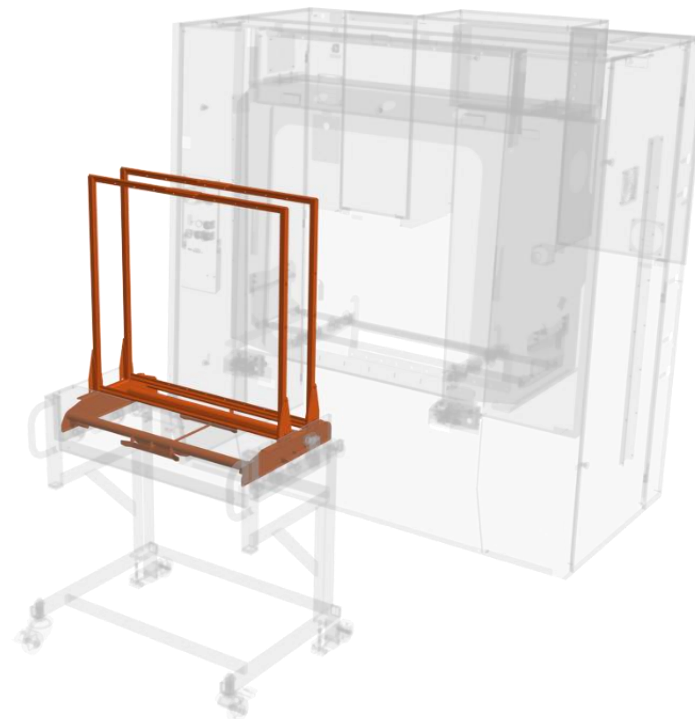

*Standard clamping usable space*

## Extra pushcart

VM-00003945-X

### Extra pushcart HySW

- Extra pushcart for basket/frame holder
- Necessary to order additional basket or frame holder

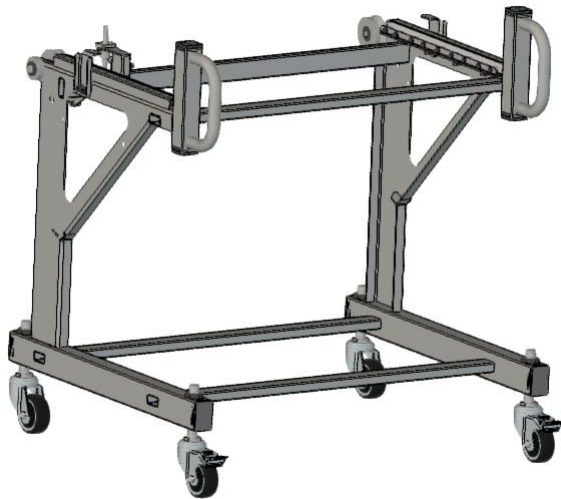

## Pushcart accessories

VM-00004543-X

### Drip tray for pushcart

- Stainless steel dip tray for pushcart
- Prevents droplets from dripping onto the ground

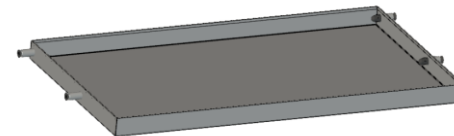

## Traceability

### VX-00000005-X

#### Traceability XML ONLINE HySW

- Designed for tracking cleaned items and allowing automatization of the cleaning process
- Automatic cleaning program selection based on the batch code
- NUC PC can be connected to LAN/Internet without any restrictions (for Windows and driver updates etc.)
- Machine standard control PC is safely separated from the Internet
- Multi-format IR code scanner – can read barcodes, DM and QR codes, etc.
- Traceability XML files are sent to NUC PC for further processing and backed-up on the standard PC
- XML files provide great opportunity for further machine processing and data analysis

### VM-00011532-X

#### Traceability XML ONLINE prep kit HySW

- Preparation kit for later retrofitting of XML Online Traceability
- Consists of NUC mini PC, communication and power cabling, as well as necessary fixation elements

Traceability

Manage batch codes

Article code mask: 1110000

Batch code: 950-BATCH

Article: 950009

Batch files: 730-BATCH.txt, 950-BATCH.txt

Article: 950001, 950002, 950003, 950004, 950005, 950006, 950007, 950008, 950009

Buttons: ADD, DEL, SAVE, CLOSE, DELETE

Batch file: SAVE, CLOSE, DELETE

Data capture delay [s]: Pressure 10, Temperature 1, Level 1, Conductivity 10, Concentration 120, Drying temperature 120

Count 9

EXIT

QR codes: CANCEL, SAVE, CLOSE, DELETE

View traceability files

File	Data
2023_10_05_10_26_08_730-BATCH.xml	<?xml version="1.0" encoding="ISO-8859-1"?>
2023_10_05_10_39_05.xml	<Machine>
	<Global>
	<traceability FileName="C:\Program Files (x86)\SSWASH\traceability_2023_10_05_10_39_05.xml">
	</traceability>
	<Result>VALID</Result>
	<Info>
	<Producer>PBT Works</Producer>
	<Serial_Number>S.N. CK230059</Serial_Number>
	<Version_SW>ver.5.14</Version_SW>
	</Info>
	<User>operator</User>
	<Time>
	<Typ_date>YYYY-MM-DD</Typ_date>
	<Date>2023/10/05</Date>
	<Typ_time>hh:mm:ss</Typ_time>
	<Start>10:26:08</Start>
	<End>10:35:26</End>
	</Time>
	<Batch>
	<Id>730-BATCH</Id>
	<Sample Number="1">
	<Code>730001</Code>

Exit

## Automatic dosing

### VM-00003850-X

#### AD Automatic Dosing Unit

- Refills the wash tank with cleaning agent concentrate and DI water according to set concentration parameters
- In combination with concentration measuring unit can work according to measured concentration (Adaptive dosing)
- Must have DI water, if not, must have external tap water connection and order *DI Water system*

### VM-00010600-X

#### AD prep kit for HySW

- Preparation kit for retrofitting of the AD Automatic Dosing Unit

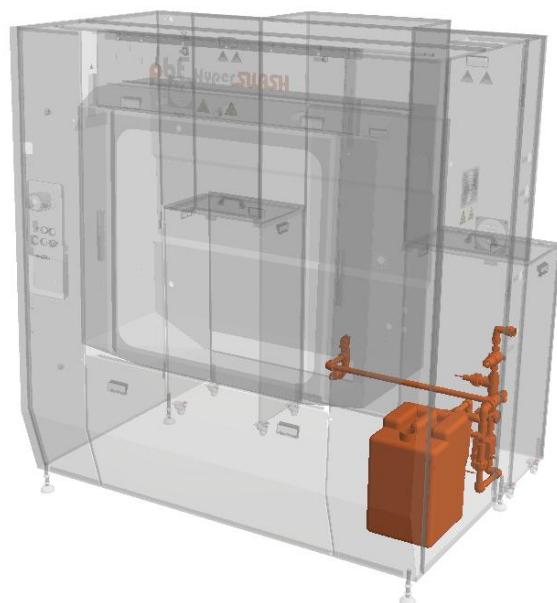

## Concentration measuring

### VM-00011463-X

#### ZESTRON EYE - concentration measuring and data acquisition system HySW

- Concentration monitoring of cleaning medium in wash loop
- Used for concentration measuring of circulated cleaning medium in wash loop
- The set includes sensor, controller, cable
- The sensor is calibrated for Zestron cleaning agents only

### VM-00011471-X

#### KYZEN ANALYST - concentration measuring and data acquisition system HySW

- Concentration monitoring of cleaning medium in wash loop
- Used for concentration measuring of circulated cleaning medium in wash loop
- The set includes sensor, controller, HMI and cable
- The sensor is calibrated for Kyzen cleaning agents
- Other chemistry calibration is possible



Wash		1st Rinse
07:20	00:00	09:58
Temperature:		Temperature:
52 °C	51.7 °C	40 °C
Conductivity [µS/cm]:		Conductivity:
30	1.9 AAD	50
Concentration [%]:		
18	18.5	
Subprocess time:		Subprocess:
1	6/0 00:00	1 2/0
2	02:00 00:00	2 01:00
3	2/0 00:00	3 2/0
4	00:00 00:00	4 00:30

## Water treatment to DI

**VM-00003451-X**

**DI Water system (1x Mixed Medium)**

**VM-00004452-X**

**DI Water system (1x Mixed Large)**

- Cart containing 1pc medium or large Mixed, piping connection
- It is used to convert tap water to DI water
- For rinse loops and/or AD dosing unit

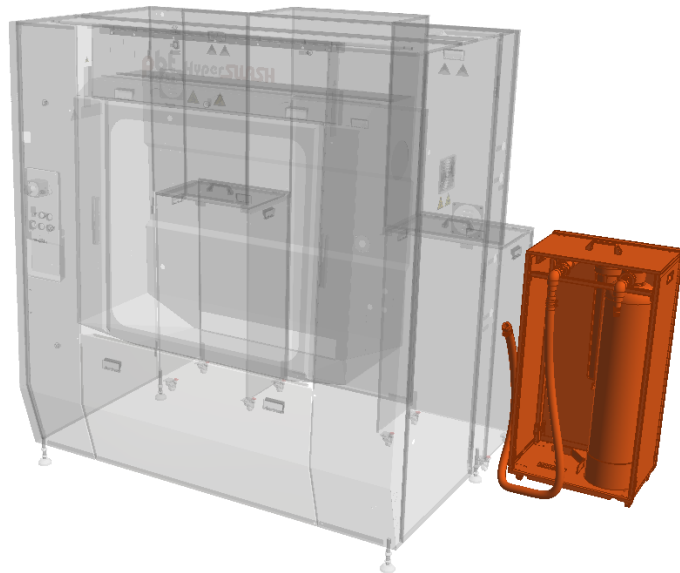

## Extra cart for filtration

**VM-00003452-X**

**Rinse filtration cart for closed loop DI Water (Carbon, Mixed Large)**

- Extra DI water replacement cart with chemical filtration and a mechanical filter
- External cart containing large Mixed and Carbon, 1µm 20" filter cartridge
- Possible to replace as for 1<sup>st</sup> rinse as well as 2<sup>nd</sup> rinse

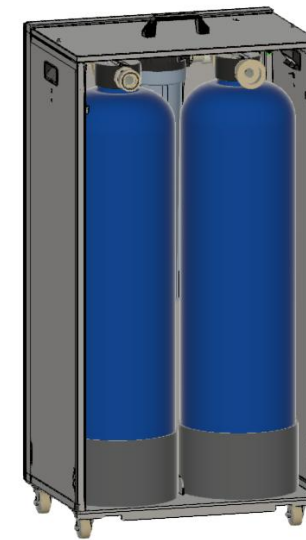

## Clamping COMBO

### VM-00004409-X

#### Basket COMBO (usable 788 x 278 mm)

- Basket for COMBO 2 or COMBO 3
- Usable dimension 788 x 278 x 165/300 mm (WxLxH)

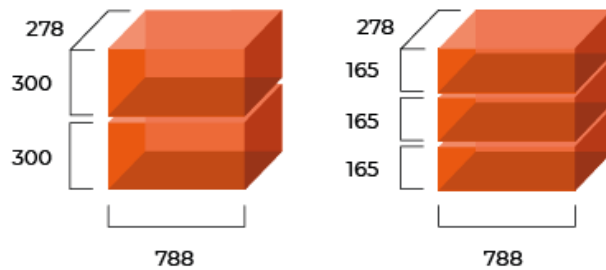
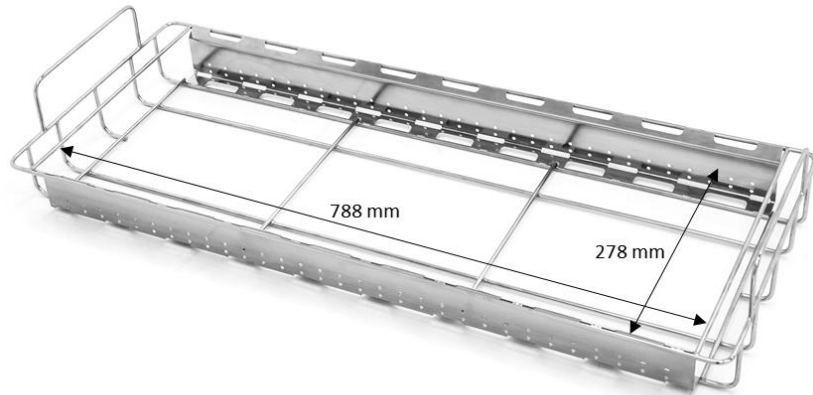

Standard clamping usable space

### VM-00004207-X

#### PCBA separator into COMBO basket, 8 positions, 26 mm spacing (1pc)

- Max 34 pcs in one basket
- Recommended 12 pcs (racks) per basket, depending on PCB dimensions

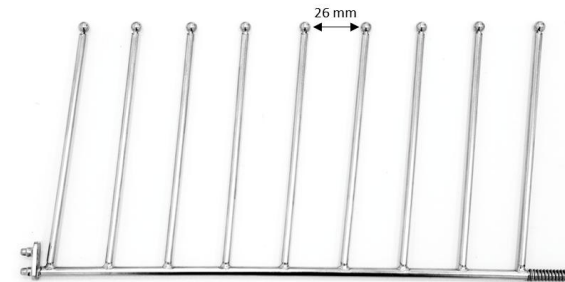

## Clamping TWINGO

VM-00001521-X

Spring Fingers Bar for PCB (vertical, pitch 50mm) into Basic Frame SuSW T, HySW, MiSW

- Adjustable vertical bar with metal fingers
- For basic frame TWINGO

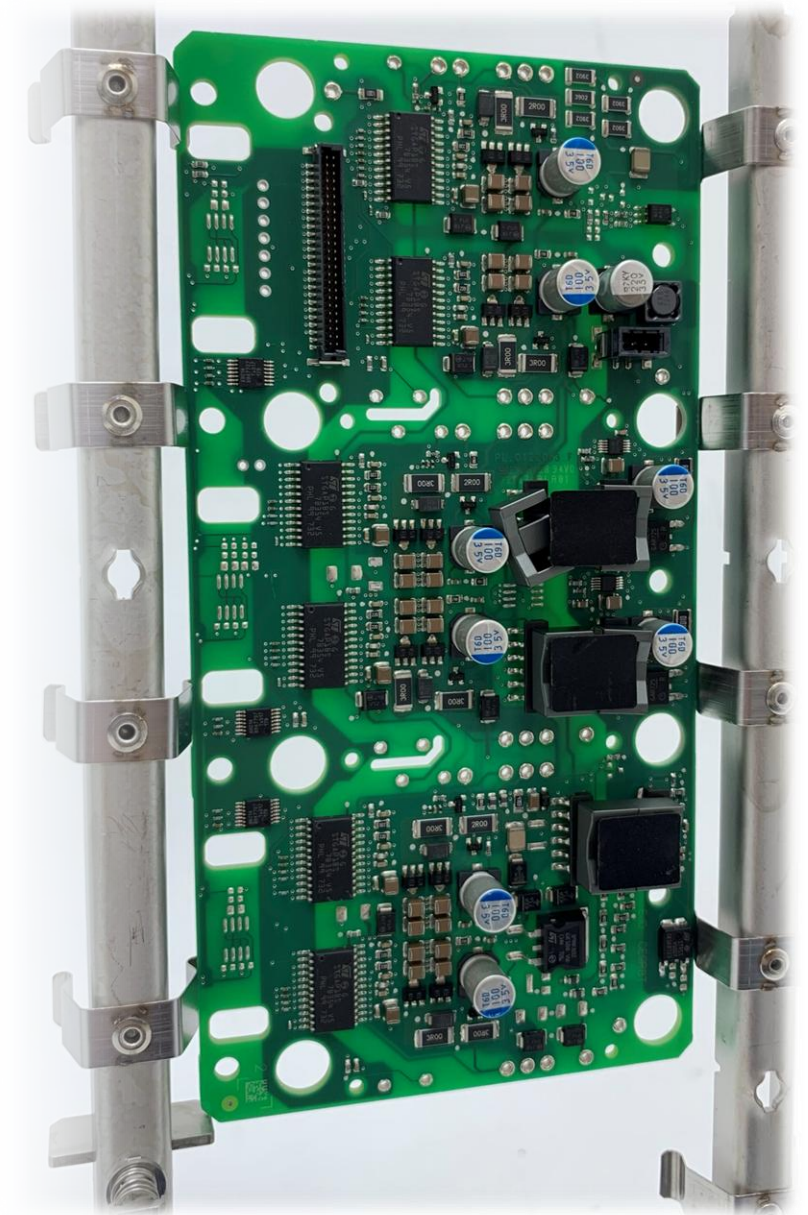
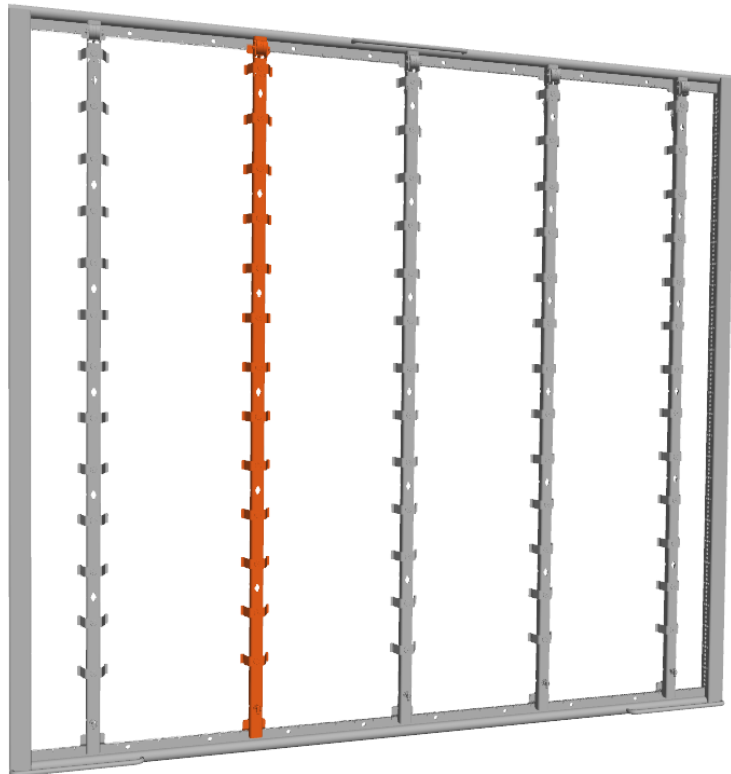

## Clamping TWINGO

VM-00001520-X

Supporting pin for heavy board (for vertical bar with spring fingers only)

- This pin holds PCB from sliding down
- To be used with Spring Fingers bar SINGLE or TWINGO only

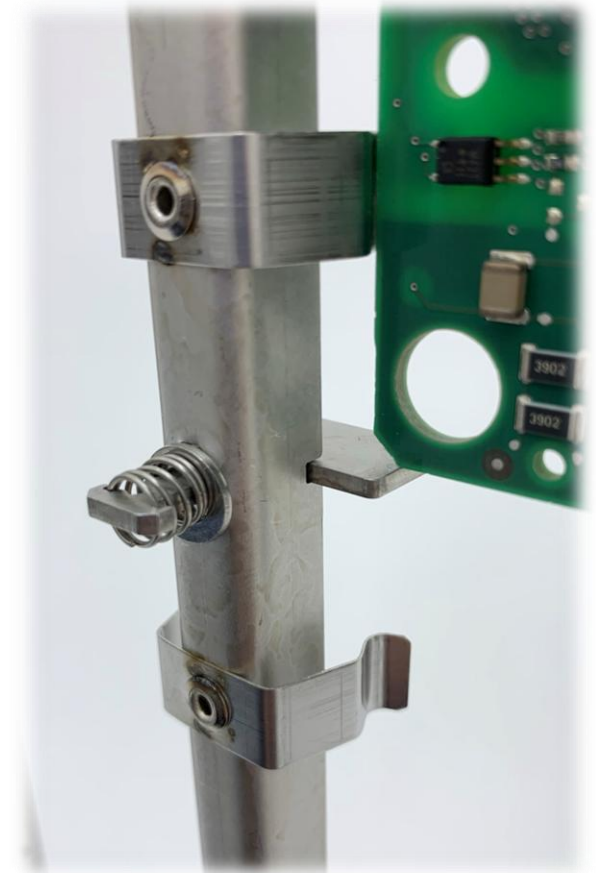
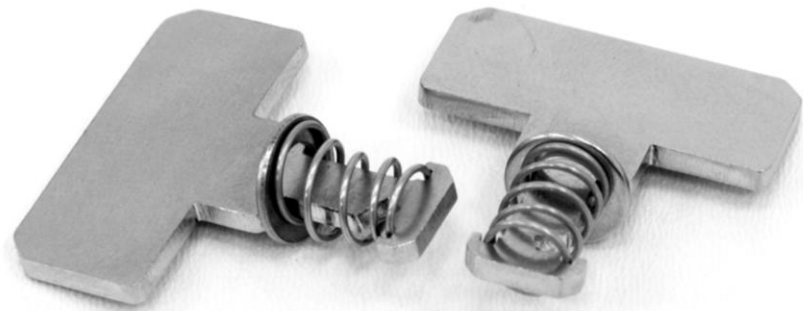

## Clamping TWINGO

VM-00004049-X

Spring Wires Bar for PCB (vertical, pitch 25mm) into Basic Frame SuSW T, HySW, MiSW

- Adjustable vertical bar with spring wires
- For basic frame TWINGO

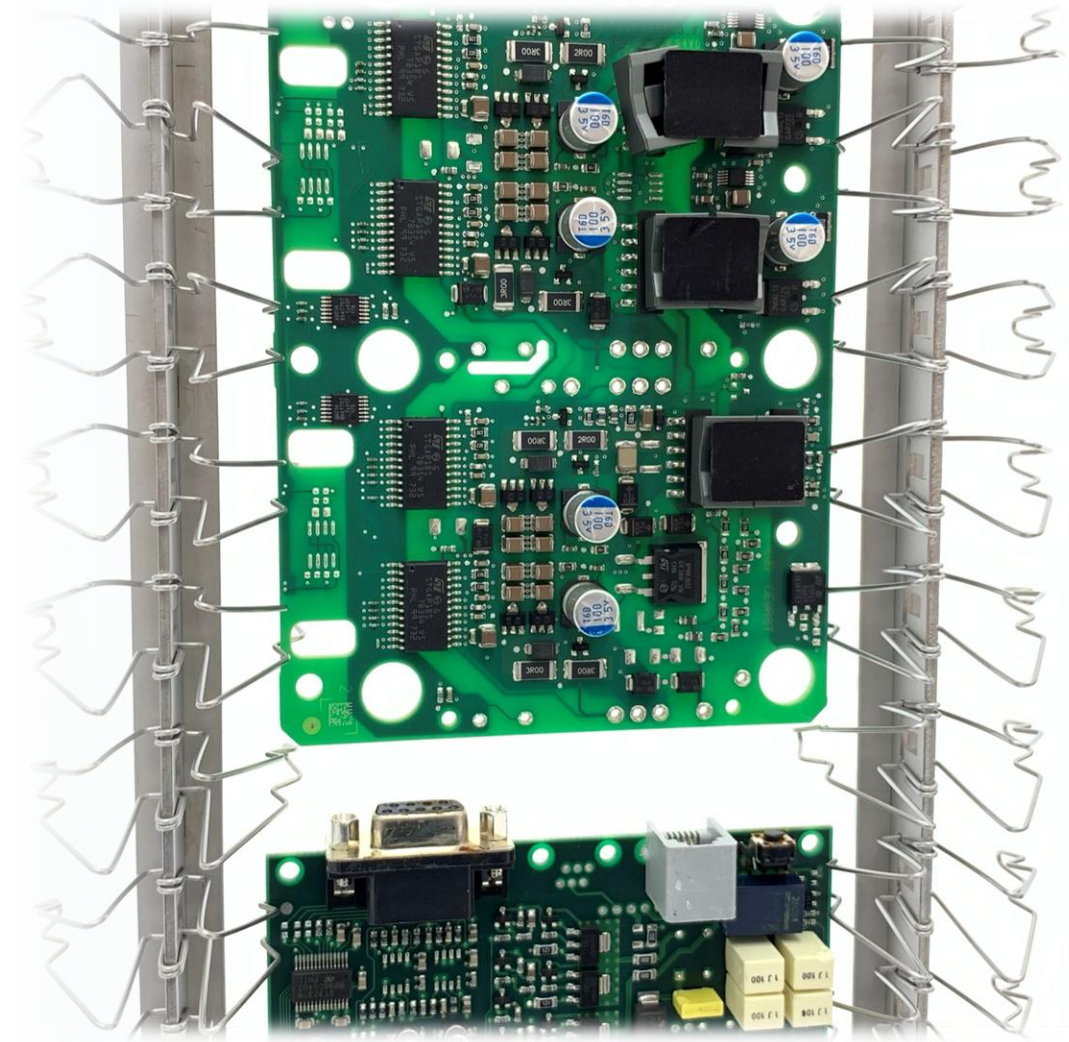
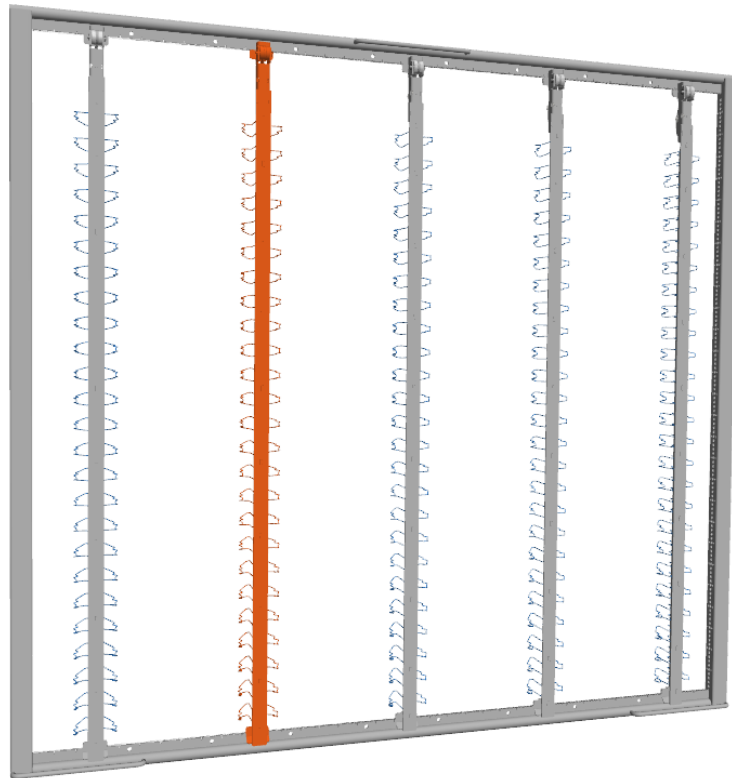

## Clamping TWINGO

VM-00003948-X

Spring Wires Bar for PCB (horizontal, T-profile) into Basic Frame SuSW S/T, HySW, MiSW

- Adjustable horizontal bar with spring wires

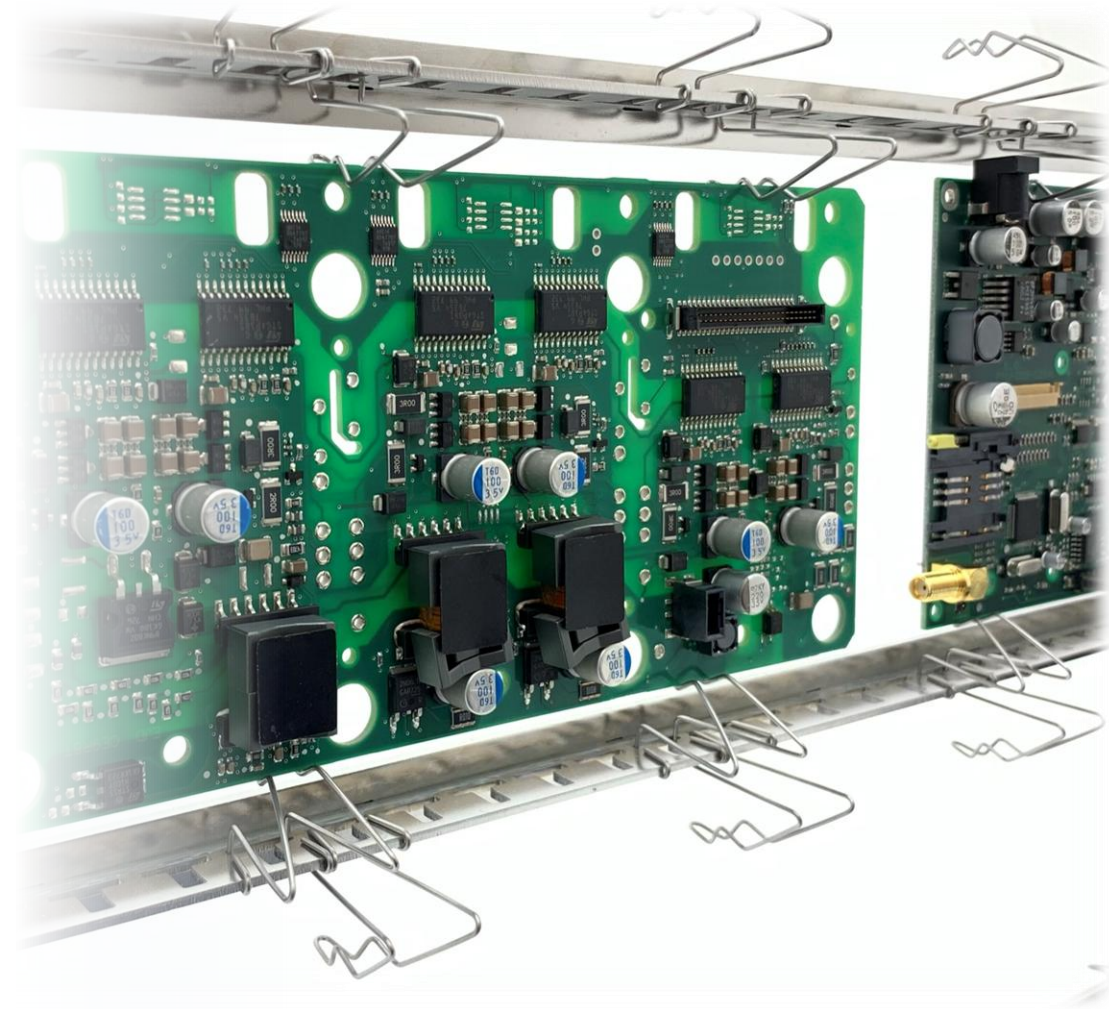
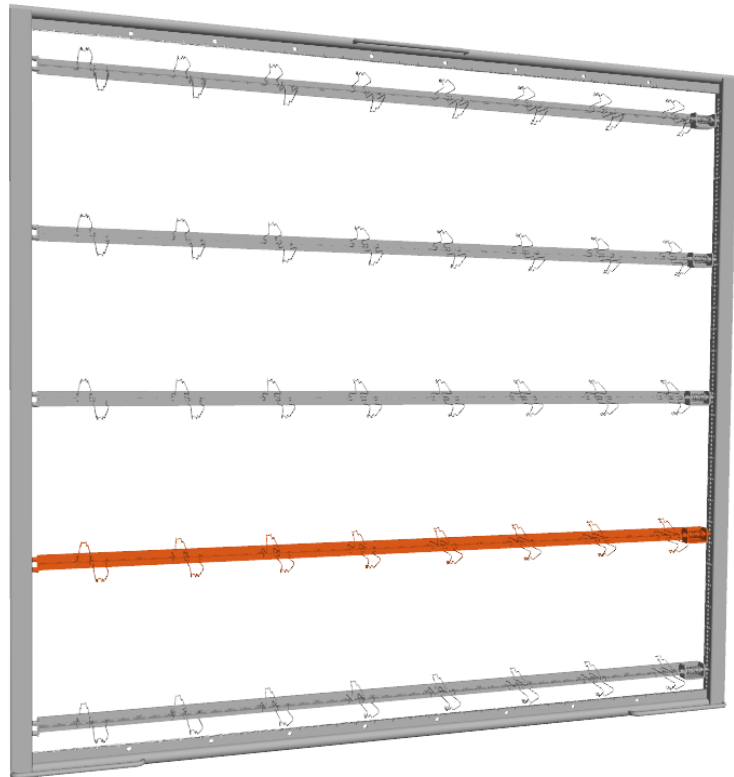

## Clamping TWINGO

### VM-00003984-X

Wire Basket 24x727x50 (WxLxH usable dim.) into Basic Frame SuSW S/T, HySW, MiSW

- Basket usable dimensions 24 x 727 x 50 mm
- Max 6 pcs/frame

### VM-00003985-X

Wire Basket 34x727x50 (WxLxH usable dim.) into Basic Frame SuSW S/T, HySW, MiSW

- Basket usable dimensions 34 x 727 x 50 mm
- Max 6 pcs/frame

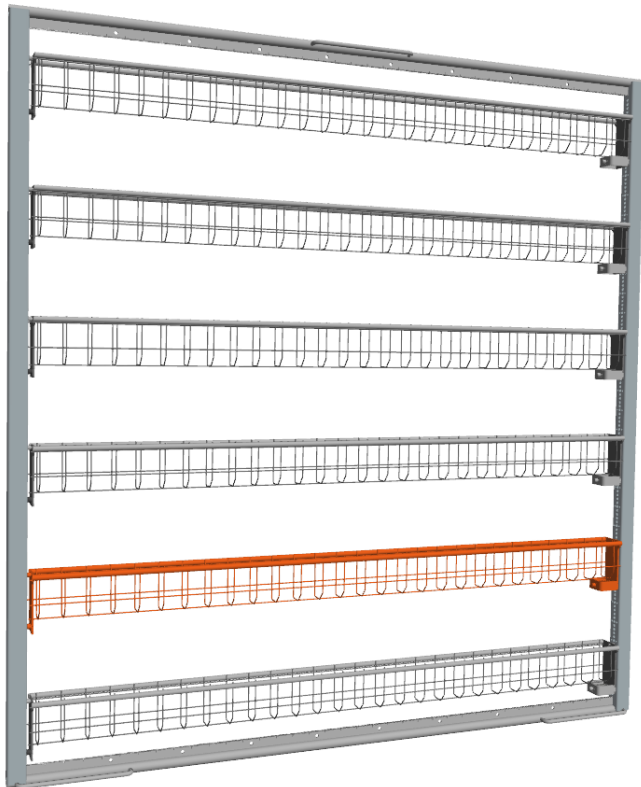

## Clamping TWINGO

### VM-0003987-X

Wire Basket 24x727x100 (WxLxH usable dim.) into Basic Frame SuSW S/T, HySW, MiSW

- Basket usable dimensions 24 x 727 x 100 mm
- Max 4 pcs/frame

### VM-0003988-X

Wire Basket 34x727x100 (WxLxH usable dim.) into Basic Frame SuSW S/T, HySW, MiSW

- Basket usable dimensions 34 x 727 x 100 mm
- Max 4 pcs/frame

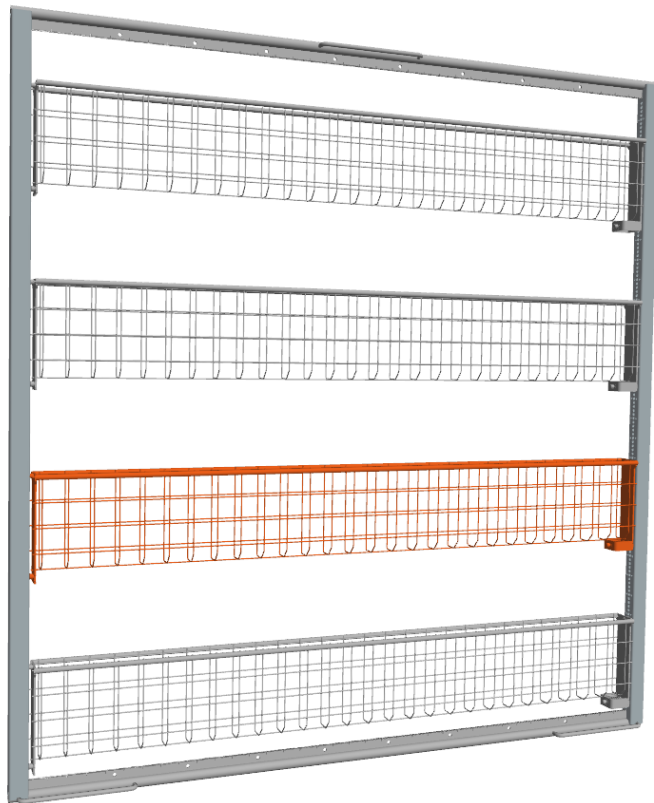

## Clamping TWINGO

### VM-00003992-X

Wire Basket 24x727x170 (WxLxH usable dim.) into Basic Frame SuSW S/T, HySW, MiSW

- Basket usable dimensions 24 x 727 x 170 mm
- Max 2 pcs/frame

### VM-00003991-X

Wire Basket 34x727x170 (WxLxH usable dim.) into Basic Frame SuSW S/T, HySW, MiSW

- Basket usable dimensions 34 x 727 x 170 mm
- Max 2 pcs/frame

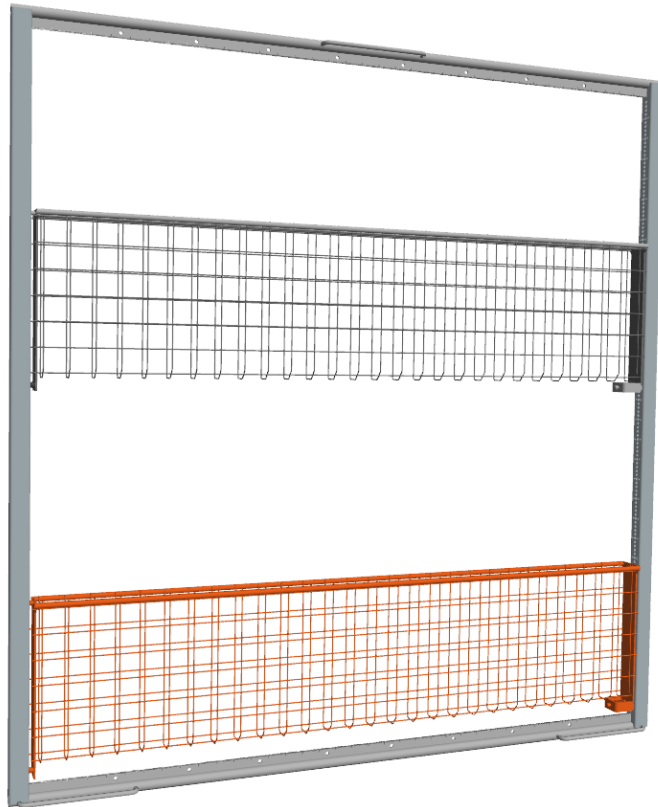

## Packing

### VM-00002683-X

Transport wooden box incl. Packing Cost (HySW/HyCL) 2620 x 1701 x 2283 mm

- Standard wooden box for machine only
- Including Heat Treatment (HT)
- Including Shockwatch shipping and handling indicator

### VM-00009948-X

Transport wooden box for 1pc pushcart 1210 x 1200 x 1650 mm

- Wooden box for 1 pushcart that comes with the machine
- Including Heat Treatment (HT)

### VM-00003363-X

Transport wooden box incl. Packing Cost (MiSW) 1386 x 2300 x 1468 mm

- Wooden box for extra pushcart and extra accessories
- For 2 pushcarts and other accessories or spares
- Including Heat Treatment (HT)



### HySW SeaPack

Sea transport packaging surcharge for HySW

- Special packaging to prevent damage from climatic conditions if maritime transport



### PHYTO\_CERTIFICATE

Phytosanitary Certificate of Heat-Treated Wooden Box

- Certificate that the wooden box meets specified import phytosanitary requirements





**PBT Works s.r.o.**

Lesní 2331, 756 61 Rožnov pod Radhoštěm

Czech Republic

[info@pbt-works.com](mailto:info@pbt-works.com)

+420 572 153 111

[www.pbt-works.com](http://www.pbt-works.com)