

# 3Si / 3Di-GX Series Product Specifications

	3D-SPI	3D-AOI
Dimensions	L	L
Model Name	3Si-LS3GX	3Di-LS3GX
Resolution	15µm	15µm
Image Capture Time	3,500mm <sup>2</sup> /s	5,600mm <sup>2</sup> /s
Height Measurement Range	500µm	25mm
PCB Size (mm, in.)	50 × 60 ~ 510 × 510 1.97 × 2.36 ~ 20.07 × 20.07	
PCB Clearance	Top: 40mm, 1.57in. / Bottom: 60mm, 2.36 in.	
Electric Power	Single Phase ~ 200-240V+/-10%, 50/60Hz	
Air Requirement	0.5 MPa @ ≥5L/min (ANR)	
Noise Level	60 dB (A)	
PCB Weight	12kg	
Weight	660kg	

Front View  
(mm, in.)

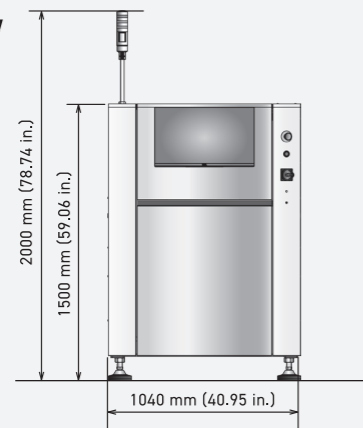

Side View  
(mm, in.)

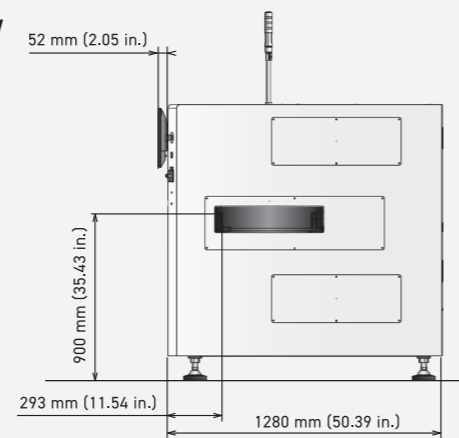

## Optical Options

### Dome Lighting

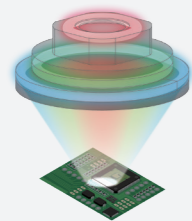

Dome lighting enhances color contrast in non-flat areas, ideal for automotive and other high-quality, high-reliability applications.

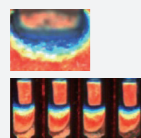

### Side Cameras



Quad side camera system ensures inspection of dead angles and areas missed by overhead camera.

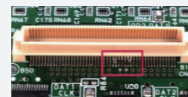

### UV Lighting

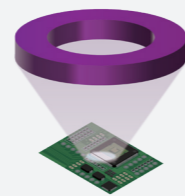

UV Lighting ensures conformal coating inspection.

Video QR

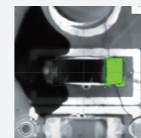

\*When selecting UV lighting, 3D inspection cannot be used together.

3D Solder Paste Inspection (3D-SPI) Systems |  
3D Automated Optical Inspection (3D-AOI) Systems

# 3Si / 3Di-GX Series



## SAKI Corporation

Headquarters Office

DMG MORI Tokyo Digital Innovation Center 3-1-4, Edagawa, Koto-ku, Tokyo, 135-0051, Japan

Tel. +81-3-6632-7910 Fax. +81-3-6632-7915

## Global Network

<https://www.sakicorp.com/en/network/>

## 3D-SPI

SAKI's 3D-SPI enable increased production efficiency with remarkable speed, as well as increased product and performance quality and takt-time control.

### Accurate 3D measurements

Multi-frequency digital projectors provide accurate 3D measurements for high-quality images and quantitatively detect solder printing failures.

#### IPC-compliant inspection quality

Positional deviation of pad size is inspected based on the IPC-7527 quality standard for measurement allowances.

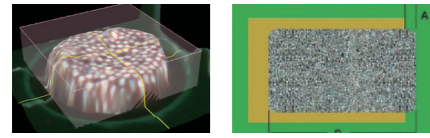

Printing Deviation Standard Paste solder printing from the pad class 1,2,3: less than 25%

#### Coplanarity inspection

High I/O count device inspections benefit from improved coplanarity, with solder range analysis for height, volume, area that helps prevent post-reflow wetting.

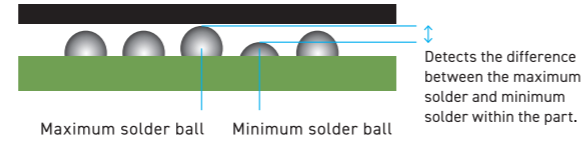

#### SPC functions for visualization of solder quality

Solder quality is managed and maintained through comprehensive monitoring of board solder amounts and defect trend analysis. Extensive reporting functions and data analysis tools allow for export of defect type rankings and yield charts.



#### Coordination with Printer

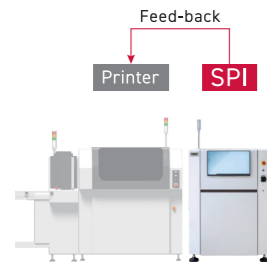

#### Feed-back from SPI to screen printer

SPI feeds back misalignment data, preventing print errors and triggering automatic stencil cleaning alerts.

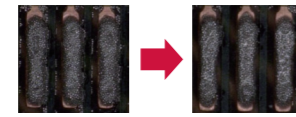

Automatic cleaning instructions

\*SAKI partners with the leading PCB equipment manufacturers. Ask us which products we connect with.

## 3D-AOI

Fully compatible with both SMT and through-hole processes, the 3D-AOI meets all quality requirements for complex inspection targets, such as high-density printed circuit boards and boards housing a mix of both extremely small and tall components.

#### Solder Fillet Inspection

"Fillet Shape" Solder Inspection Algorithm supports the inspection of various types of components and enables solder fillet inspection in compliance with IPC inspection standards.

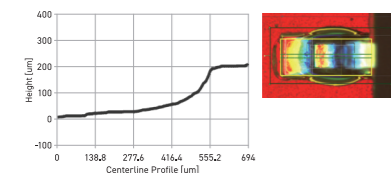

#### THT Solder Inspection

The FUJIYAMA solder inspection algorithm has been upgraded. In addition to the inspection of pins, holes, and solder fillets, further functions now also inspect for overabundance excessive solder.

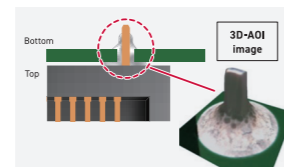

#### Full Surface Inspection for Foreign Objects & Solder Balls

This feature detects foreign bodies and fallen objects across the entire board. With the latest software, solder ball detection tests can be conducted across the entire board simultaneously with normal foreign object inspection.



#### OCR Inspection

Achieves high-precision inspection of characters and polarity on components with a maximum component height of 10mm. By focusing on both the board surface and the component surface, solder inspection and character polarity inspection can be performed simultaneously.

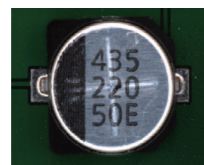

#### UV lighting for Conformal Coating Inspection

Defects whether the entire PCB has been coated. Simultaneously identifies foreign materials, ensuring superior inspection quality.

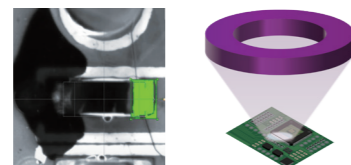

#### Offline Debugging

In a mass production environment, this feature visualizes operator assessment results (false calls, NG) and adjusts inspection parameters accordingly.

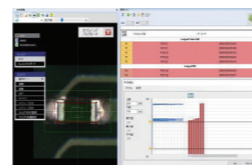

## Advanced Software Solutions

### Optimize your production line with the latest software.

Expected effect ▶ Unified user interface across SPI, AOI, and AXI ▶ Increased work efficiency for inspection program creation.  
▶ Enhanced production with AI-AOI with improving inspection quality.

### Easy Programming

- Decrease programming time and effort with automated creation of inspection program
- Eliminate programming errors with comprehensive automated inspection data creation

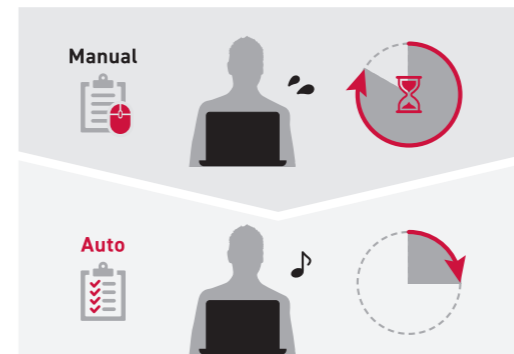

### One Programming

Standardized inspection program data for SPI, pre-AOI, and post-AOI, eliminates duplicate tasks and reduces line setup by approximately 30%.

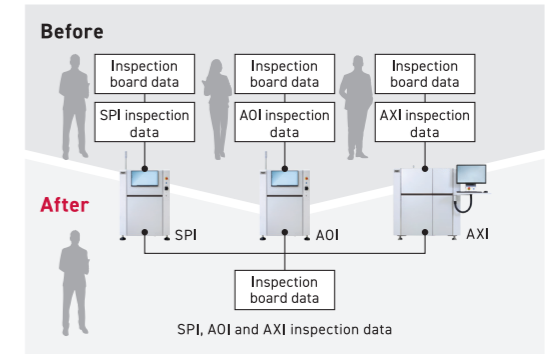

\*AXI support scheduled for 2026

## SAKI Link

SAKI's SPI-AOI are linked to improve the efficiency of inspection.

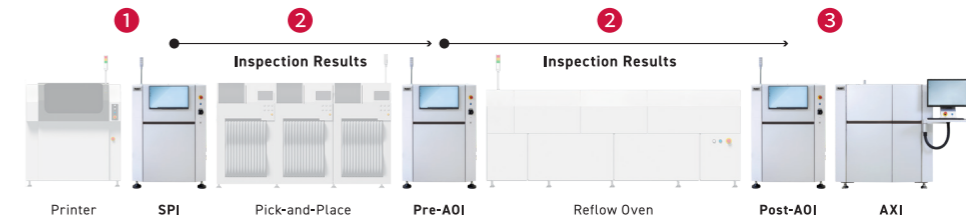

#### 1 One Operation Control

All inspection machines can be operated from a single unit

Load a single inspection program to start/stop all connected devices automatically.



#### 2 Process Check

Prevent defective boards from moving to post-processing

If an upstream inspection machine flags a board as NG, it is marked as an "Operation Error".

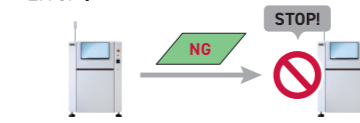

#### 3 Bad Board Skip Function

Reduce X-ray inspection time

Sharing AOI inspection results with our X-ray machine, enabling bad-marked boards to be skipped.



## AI solutions

### AI Assist

Uses AI to re-assess, reducing operator workload

AI performs a second assessment on parts marked NG, drastically reducing the operator's workload by requiring manual verification only for AI-determined NG parts. This system helps prevent overlooked errors caused by misjudgement.

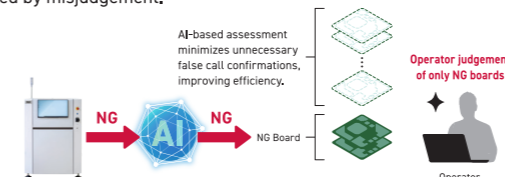

### AI Inspection (AI OCR)

Ensures consistent inspection quality without operator expertise

AI OCR detects and recognizes characters, enabling stable inspection regardless of print misalignments or font variations.

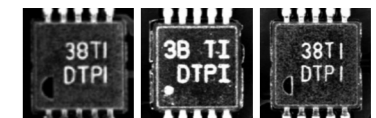

It overcomes discrepancies from different part manufacturers.