

Automated Optical Inspection System

Inline High Resolution, High Speed

BF-Planet XII

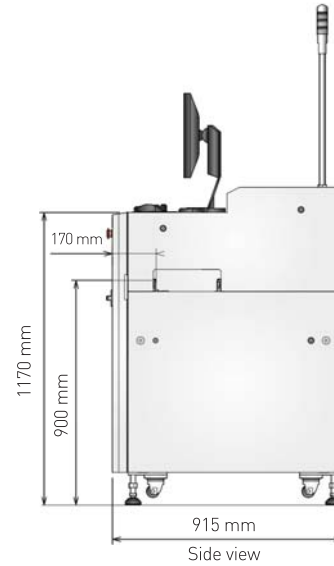

High Resolution Imaging System

With a superior resolution of 10µm and scanning line color CCD camera, BF-Planet-XII provide accurate and stable inspection results. Solder fillets on components as small as the high density mounted 01005 (0402) chip, as well as IC's with 0.4 mm pitch lead are easily inspected and analyzed.

High Throughput

BF-Planet-XII has Saki's original alternate scanning system that captures several lighting images in one scanning. Newly developed color capturing system enable to make scanning speed twice faster than previous model. It takes only 9 seconds to capture M-size board (250 mm x 330 mm). Overall tact time including inspection also become shortened dramatically.

Advantage of Line Scan Visual Inspection

Extra components on the board can be detected only by setting up one inspection window on the whole board. It is realized by the advantage of line scan method.

Coaxial Overhead Light

Soldering condition is inspected by illuminant irradiation of coaxial overhead lighting. Inspection is not affected by shadowing by neighboring tall components, therefore same library is available at any location on the board.

Specifications

Model	BF-Planet XII
Resolution	10 µm
Board size	60 x 50 - 330 x 250 mm
Board thickness	0.6 - 3.2 mm, 24 - 126 mils
Board warp	+/-2 mm, 79 mils
PCB clearance	Top: 40 mm, Bottom: 40 mm
Rotated component support	Available for 0 - 359° rotation (unit of 1°)
Inspection categories	Presence / absence, misalignment, tombstone, reverse, polarity, bridge, foreign material, absence of solder, insufficient solder, lifted lead, lifted chip, and fillet defect. Each defect name can be changed freely by system function.
Tact time *1 *2 (330 x 250 mm)	Approx. 18 sec.
Image scanning time *1 (330 x 250 mm)	Approx. 9 sec.
Camera (image processing)	Line color CCD camera
Lighting	LED lighting system
Transfer conveyor method	Flat belt transfer
Transfer conveyor height	900+/-20 mm
Transfer conveyor width adjustment	Manual
Operating system	Windows XP english version
Optional system	BF-Editor / BF-RP1 / BF-monitor / BF-view
Optional	2D Barcode recognition, journal printer, Automatic transfer conveyor width adjustment

*1 If PCB size is smaller than 330 x 250 mm, Image scanning time will be shorter than these values. *2 Including image scanning time.

Installation Specifications

Electric power requirement	Single phase -100 - 120 V/200 - 240 V +/-10%, 50/60 Hz
Power consumption	500 VA
Air requirement	0.5 MPa, 5L/min (ANR), 73 PSI, 0.18 CFM
Usage environment	15°C (59F) - 30°C (86F) / 15 - 80% RH (non-condensing)
Noise level	57.5 dB
Dimensions W x D x H	600 x 915 x 1270 mm
Weight	Approx. 275 kg, 607 lbs

New Interface

Renewed user interface makes it easier to set up inspection data by using pre-installed Saki standard library. And optional new function KPK, that finds out the difference between surface of the board and the surface of component automatically, simplifies to detect missing component. This realizes time reduction for inspection data making at launching production.

Flexibility

BF-Planet-XII has 40 mm clearance at the top side of the board and 40 mm at the bottom side. It enables most of the PCBs with tall components. In addition, BF-Planet-XII can be used in any stage of the PCB production process from post-print, post-mount, and post-flow/reflow, or manual mounting.

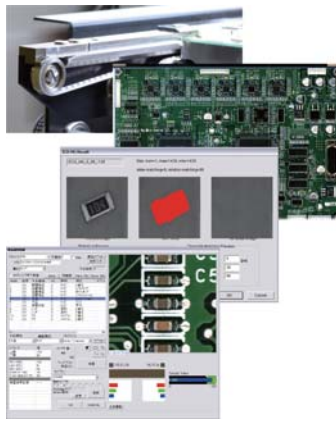

Traceability

Optional function of BF-Planet-XII can read all types of barcode and 2D code on the board. Inspection output is reported with code number. It enables easy SPC data handling and log data management on manufacturing lines.